



Modification of Drain Hayward Strainer Pipe Header Pipes to Improve Efforts of Cooling Water Pump Train E F Badak LNG Bontang

Murni*, Riky Ferdiyanto, Seno Darmanto, and Didik Ariwibowo

Mechanical Engineering, Department Vocational School of Diponegoro University
Jl. Prof. Soedarto, SH. UNDIP, Tembalang, Semarang, 50275, Indonesia

e-mail : mochmurni@gmail.com

Abstract - In Badak LNG the role of the cooling water pump is very important, and becomes the main support for transferring sea water where the water is used in the cooling process of industrial machinery or as emergency safety for firefighters. Water pump cooling has a hayward strainer that serves to filter water with a smaller filter so that the cooling water that is sent is completely free of dirty water. The purpose of this final project is to find out the main causes of the performance degradation of the EF cooling water pump due to the barrier to the hayward strainer which results in lower pressure on the cooling water. The methodology applied was based on field observations and conducted a solidwork simulation test. Field observations show that when more than one hayward strainer is in backwash, the effectiveness of backwash release decreases because the main disposal of the hayward strainer becomes one. The solidwork simulation found that the pressure on the Hayward train E strainer was high enough to create back pressure and limit the flow of the Hayward strainer outlet. By performing actual simulations by only running only one exhaust system at Hayward train E trainer has improved performance on the hayward strainer system. The performance analysis of the cooling water pump was carried out to determine the cause of the pump pressure drop on the hayward strainer and it was found that the main cause of performance was due to back pressure disposal, the pressure was increasing at each outlet of the Hayward strainer which had more distance to the outlet drain. Taking into account the problem of back pressure, separating the train E and F cooling water pump lines is a good choice. After simulating solid work, the separation of the E train line and the F colling water train shows an increase in the performance of the cooling water pump system because the Hayward strainer runs well so that the pump pressure is maintained for the industrial engine cooling needs.

Keywords – Hayward Strainer, Pipe, Drain, back pressure, Cooling water pump

Submission : May 2, 2018

Correction : November 19, 2019

Accepted: November 20, 2019

Doi: <http://dx.doi.org/10.14710/jvsar.v1i2.4815>

[How to cite this article: Murni, Ferdiyanto, R., Darmanto, S., Ariwibowo, D. (2019). Modification of Drain Hayward Strainer Pipe Header Pipes to Improve Efforts of Cooling Water Pump Train E F Badak LNG Bontang. *Journal of Vocational Studies on Applied Research*, 1(2), 17-21. doi: <http://dx.doi.org/10.14710/jvsar.v1i2.4815>]

1. Introduction

All of the Cooling Water Pumps (CWP's) are equipped by the Hayward Strainer (HWS) for filtering the dirt, scale or any matters which may harm and plug in the CWP's downstream equipment. Originally, the backwash is controlled by preset timer that will automatically backwash the HWS every 4 hours in 20 minutes. However, the backwash also automatically runs if the pressure differential (PDCH) reach 0.8 kg/cm². Currently, besides that two logic operation sometimes perform individual backwash to ensure the delta pressure between upstream and downstream high that could result the motor low-low

amperage (PALL) triggered (CWP's Motor Trip)[1]. The problem when more than one HWS in backwashing, the effectiveness of releasing the backwash decreases due to the backpressure from neighborhood HWS. It directly results event that Utilities II Operators need to stop the Others HWS backwashing, prioritizing the HWS that has higher pressure differential.

2. Experimental Procedure

The final project that discusses the modification of the drain hayward strainer pipeline to improve the performance of the EF water train does not exist yet, so that

the compilers make the final assignment with the title as for the problems so that the cooling water performance decreases is based on experience to reduce the risk of system failure cooling water is very vital and the author has a different discussion. In this final project report, the author will discuss the modification of drain hayward strainer which is applied as an alternative pathway to facilitate the work system of drain hayward strainer so that it does not interfere with other work systems in the hayward strainer. The compiler also innovates by making plans in making modifications so that they are expected to be made and applied later. The reason for the planning is mainly because the manufacture and modification required the right time to avoid the risk of failure of the EF train cooling system.

3. Result and Discussion

3.1. Previous Sewer Design Hayward Strainer

To make modifications, first it takes data from the previous design. The data obtained from the previous design, the following figure is the design of the display tool and the system of working hayward strainer in maintaining the cleanliness of cooling water [2].

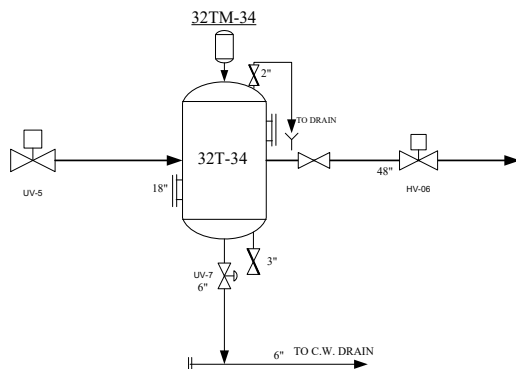

Figure 1. Tool Display Design

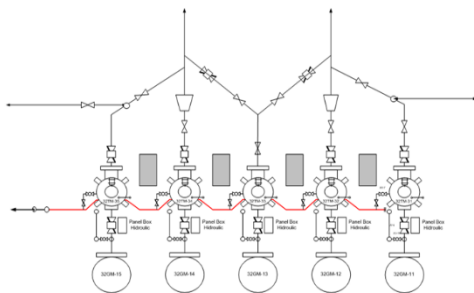

Figure 2. Design of the top View Tool Display

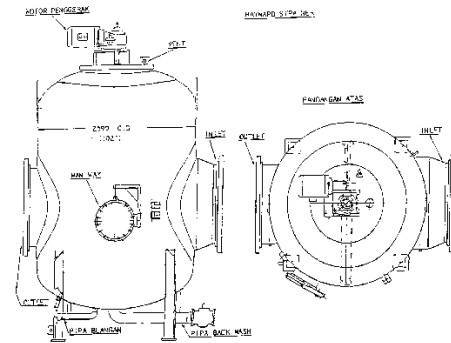

Figure 3. Hayward Strainer

3.2. Solid Work Apk Testing

From observation and simulation by Solidworks, the 10 inch header pipe cannot accommodate the flow released by the hayward strainer outlet at the same time. The simulation found that the pressure at 32TM-11 and 32TM-12 is high enough to create back pressure and limit the flow of the Hayward strainer outlet. Pressure is increasing at each outlet of the Hayward strainer which has more distance to the outlet drain.

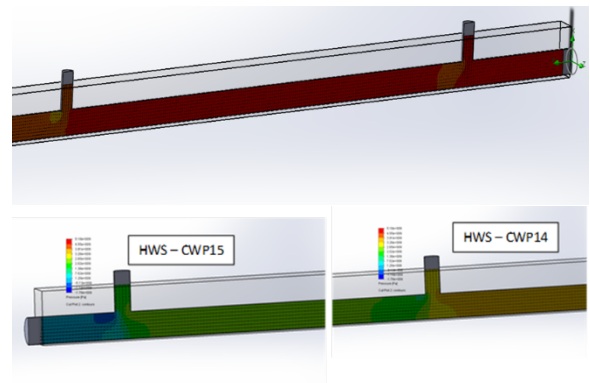

Figure 4. Simulation result

From the simulation using the solidwork by separating the line drain line E and the line drain F hayward strainer, the positive data obtained is where the line drain E has decreased resistance at the back pressure so it is expected that the performance of the hayward strainer on line E and line drain F works well and optimally[3].

3.3. Material Composition Testing

From the history of the history of cleaning the Hayward strainer, especially on the E 32-GM-11 train pump, it was found that cleaning strainer elements were often carried out and examination of the hayward strainer with frequency of cleaning twice a month and sometimes even cleaning that was not planned so as to create a cost burden in work[4].

Taking into account the problem of back pressure, there are two options for reducing back pressure by increasing the size of the header pipe and / or by separating the line drain line E and the line drain F cooling water pump.

Table 1. Cleaning History of Hayward Strainer UTILITIES

NO	Peralatan	Deskripsi	Tanggal	Shift On Duty	Time	Frekuensi
1	32-GM-11	Cleaning	06 Juni 2018	Shift Malam	8 Jam	18 Hari
2	32-GM-11	Cleaning	15 Juni 2018	Shift Malam	9 Jam	9 Hari
3	32-GM-11	Cleaning	24 Juni 2018	Shift Pagi	8 Jam	8 Hari
4	32-GM-11	Cleaning	19 Juli 2018	Shift Pagi	8 Jam	25 Hari
5	32-GM-11	Cleaning	25 Juli 2018	Shift Pagi	9 Jam	6 Hari
6	32-GM-11	Cleaning	08 Agustus 2018	Shift Sore	8 jam	14 Hari
7	32-GM-11	Cleaning	20 Agustus 2018	Shift Pagi	8 jam	12 Hari
8	32-GM-11	Cleaning	4 September 2018	Shift Pagi	9 Jam	14 Hari

3.4 Individual Backwash Test

From the actual test using the individual backwash method, namely by stopping the backward system of the hayward strainer operating and only running one hayward strainer which has a high pressure difference and farther away from the exhaust ie 32TM-11 found a hayward strainer system at 32TM-11 it runs very well and the pressure difference returns to normal, but for the dismissed hayward strainers the pressure difference increases significantly, so the operator utilities II must be alert and monitor the increase because it can cause new problems.

4. Alternative Repair Methods

From the problems found, with the design changes in the line drain line Hayward Strainer, the expected problems can be solved. The design design in making the Hayward Strainer drainage system that will be made can be seen in the following figure :

4.1. Modified drain Design for Hayward Strainer

From the site survey, the pipe routing at the area is quite crowded. Therefore, the best option is to separating the Train E & F Backwash line as depicted in Figure 3. The new line will have same specification (10"- UR0U).



Fig. 1. Hayward Strainer Area

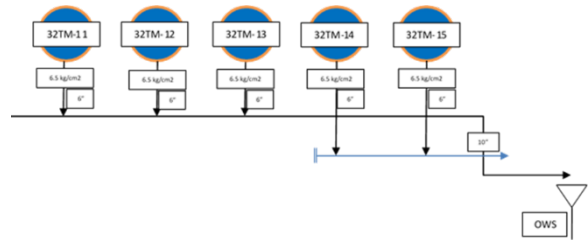

Figure 2. Simple Pipeline Diagram of HWS Backwash Path Modification

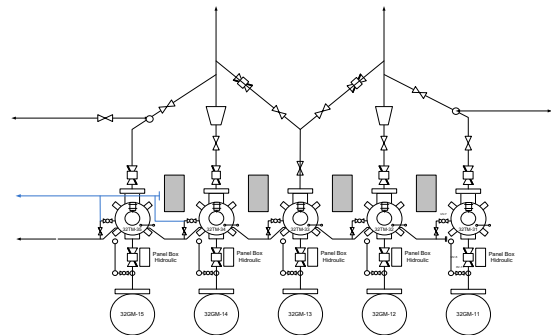

Figure 3. Modification of the Display Appearance Tool Design

4.2. HWS Drain Modification Track Making Schedule

The schedule for follow-up to the E-F Shutdown Program, proposed to ensure that no. 11-15 cooling water that runs during the project is carried out by considering the changes in the drain drain modification of Hayward Strainer. This project will last 10 working days as below.

Table 2. Modification program schedule

No	Work Description	Day -10	Day 1	Day 2	Day 3	Day 4	Day 5	Day 6	Day 7	Day 8	Day 9	Day 10
1	Material Preparation											
2	Pipe Cutting											
3	Pipe Patching											
4	Line Routing											
5	Pipe Servicing											
6	Punch List											

4.3. Procurement of Tools and Material

Procurement of piping system tools and materials are components needed for the process of making piping systems. The piping system component consists of standard components (available in logistics) and several components that must be made.

The standard component is a component that is already available in logistics, making it easy to find.

Components made are components that are not available in the market so that these components must be

made. Components made must be in accordance with the design that has been made[5].

4.4. Assembly of Piping System Components

FRP pipe assembly method applied at PT. Rhino is a Hand Lay Up Wrapping method. Hand Lay Up wrapping method is a method by wrapping FRP pipes that will be joined using matt or roving material that has been lubricated with resin

The following is the steps of the FRP pipe assembly process which will be connected with the Hand Lay Up Wrapping method [6]. The assembly steps are:

- a. Prepare work equipment, in the form of hand grinding, rollers, brushes and scissors.
- b. Prepare materials or materials, in the form of matt, roving and resin.
- c. Based on the surface of the pipe to be connected using a hand grinder. This process is done so that the fixing layer can stick perfectly to the surface.
- d. Clean the surface of the dirt that attaches to the surface of the pipe to be connected, such as mud, dust and water which results in the surface to be connected wet. Make sure before the connection is made, the surface is clean and dry.
- e. Apply resin to the surface to be joined, so that the first layer can stick well.
- f. After the resin has been applied, continue with a matt layer followed by resin. Each layer must first be smeared with resin, so that the layers can be bonded well.

For calculation of curing time after doing fiber wrapping in a FRP pipe or PVC pipe for PT. Badak NGL is needed for approximately 12 hours to get strong results on the fiber connection to get good results.

The second assembly is to put a fiber pipe and a 6 inch block valve on the modified drain system that will be made. The first process is connecting a 6 inch block valve with a drain Hayward Strainer according to the size of the design results. Then connect with a modified header pipe that will be installed, so that it will form a two-way system that will become the new Hayward Strainer disposal system.

In the painting process, surface preparation is the most important considering the basic adhesion of paint depends on surface preparation, type of surface preparation depends on recommendation, S-2½, ST-2 or ST-3 or according to recommendations, after cleaning the surface so that cleaning avoid dust or other dirt[7].

In making a mixture of painting materials used to coat Fiber pipes, the following steps are needed:

a. Preparation

At this stage it starts with preparing raw materials in accordance with the paint formula to be made. Materials taken from warehouses that have been tested for quality, do not expire and are not defective or damaged both physically and chemically (which is characterized by changes in odor, color, shape, or

thickness of the material). Read the instructions before mixing

Measuring the material to be processed, can be done by weighing it or measuring its volume, depending on what basis is used in the formula. Accuracy and accuracy of weighing are important factors in the final result of paint making, especially in the additive or pigment weighing.

b. Production

The paint production process is divided according to the type of paint to be made:

Paint without Pigment, Extender or Filler The production only involves the process of pouring, mixing and stirring, which is pouring ingredients in a sequence and manner according to the type of paint to be made into a tank of the right size. Then mix the ingredients with the mixer round relatively slowly, to obtain a mixture that is completely evenly distributed at all points. Stirring times and mixer speeds are adjusted according to the amount and thickness of the mixture.

c. Stage of Painting

In this stage special preparation is needed to coat the fiber pipe to be coated and in order to require regular steps so that the layer has strength and has a good period of use, there are several stages in painting for fiber including:

• Primary

Primer is a base or base where other coating systems are placed.

• Intermediate Coat

As an additional protection barrier and also called a body coat to add thickness and resilience. The intermediate formulation is very important. Primarily to increase thickness which can improve the main properties of the coating.

• Top Coat

Is a layer of sealing (a resinous seal) above intermediate and primary. This is the first defense against an aggressive chemical, water or environment that functions as the first barrier in a system coating.

5. Conclusions

- a. The decline in the performance of the cooling water train pump E is due to the inferior drainage system of the hayward strainer because it only consists of one exhaust header line which has a large effect on the drain on the pump train E so that the pump train E often experiences cleaning the hayward strainer faster than other pumps so it affects Pump train performance E
- b. FRP has chemical resistant properties, but brittle, FRP is widely used in PT BADAK, which is generally used in the area of the Cooling water system and chemical units and is used in areas with low pressure FRP after wrapping the resin still requires time or curing time up to 24 hours, the most

important thing to note in FRP dressing is that the thickness in the dressing is at least the same as the thickness of the original equipment or pipe.

6. Recommendations

- a. Modifying the path of disposal of the hayward strainer is separate between upstream and downstream.
- b. F&PE Section is requested to design Hayward Strainer drain design and investigation.
- c. Use standard material accordance

7. Acknowledgment

The author thank to: First, Mr. Ir.H.Murni, MT, and Mr. Erlangga Yudha Pratama, as my assigned lecturers who always provide the guidance and direction both in lessons and report making. Second, my family especially my wife who always supports me all the time. Third, Raffan and Rafifa as my fun time. Fourth, All PT.Badak LNG co-workers in Department Operation, Maintenance, and Shift Bravo who assist in the process of collecting data for the final assignment..

References

- [1] Badak LNG, 2009, Basic Operator Training Cooling Water, HR Department, Training Section, Bontang.
- [2] Badak LNG, 2014, Utilities Manual Book "Cooling Water and Fire Pump", Operation Department, Bontang
- [3] Inspection Team. *Inspection Report*. 2016. Bontang : PT BADAQ NGL.
- [4] Badak LNG, 2018, Log Sheet Data Plant 32, Utilities , Operation Section.
- [5] Operation Development Program. BUKU PELATIHAN JOB SPECIFIC TRAINING. Bontang. PT Badak LNG 2004.
- [6] Hatta, FIPC Team. *Painting, Coating, Fiberglass and Insulation Management*. 2016. Bontang : PT BADAQ NGL.
- [7] Inspection Section. *General Spesification for Painting Rev. 11 in PT BADAQ NGL*. 2016. Bontang : PT BADAQ NGL.