

Relationship of Cephalopods Orders Based on Morphological Characters

Nova Mujiono^{1*} and Putri Sapira Ibrahim²

¹Research Center for Biology, Indonesian Institute of Sciences
Jl. Raya Jakarta-Bogor No.Km.46, Cibinong, Bogor, Jawa Barat 16911 Indonesia
²Research Center for Oceanography, Indonesian Institute of Sciences
Jl. Pasir Putih 1 Ancol Timur, Jakarta Utara 14430 Indonesia
Email : nova.mzb@gmail.com

Abstract

Biodiversity is vital in our daily life. As a maritime country, Indonesian waters harbor many valuable animals such as Cephalopoda. Indonesian waters are rich in various species of cephalopods. Several previous studies on Indonesian cephalopods have been published, from the fishery aspect, only a few studies from the biological aspect. Information on their diversity is still scarce. It may be because the low rate of knowledge delivery from the expert to the peoples. Specimen collection is the primary source to conduct a systematic study. The present study aims to introduce the knowledge of the morphologically based taxonomy of Cephalopoda. Using the museum specimen in MZB, we made an introduction on how to distinguish the six orders of Cephalopoda. Only good preserved specimens used. Because this study intended to introduce the morphology, the specimens dissected to show the buccal mass and funnel parts. We selected one species as a representative of each known orders. The morphology was photographed using a camera for the large body parts and using a microscope for the small body parts. A phenogram based on the eleven comparative morphologies is constructed. Three main branches were identified. Nautilida was separated because of the presence of external shell and arm without suckers. Two other branches were mainly grouped based on the number of arms. Nautiloidea is consist of only Nautilida, a group whose bearing external coiled shell and arm without suckers. The other five orders are classified in Coleoidea, a group whose internal reduced shell and arm with suckers.

Keywords: Cephalopods, diversity, mollusca, morphology, specimen.

INTRODUCTION

Cephalopoda is a class in the phylum Mollusca. It comprises more than 800 known living species which can be classified into six orders (Sweeney & Roper, 1998; www.molluscabase.org). As a maritime country, Indonesian peoples are familiar with these animals. Commonly they known as cumi-cumi (squid/Teuthida), sotong (cuttlefish/Sepiida), and gurita (octopus/Octopoda). They are widely exploited as highly valuable marine products. The export volume and value of "cumi-sotong-gurita (known as CSG)" from 2014-2018 were continuously increased from 89.190.000 tonnes (161.600.000 US\$) to 121.820.000 tonnes (399.860.000 US\$) (Ministry of Marine and Fisheries, 2018). Three other orders i.e., nautilus (Nautilida), deep-sea webbed octopus (Vampyromorpha), and ram's horn squid (Spirulida) are not so popular because they are non-consumable cephalopods.

Several previous studies on Indonesian cephalopods have been published. They mainly studied from the fishery aspect (Marthinus & Ahmad, 1996; Theresia *et al.*, 2013; Muchlisin *et al.*, 2014; Samudra *et al.*, 2016; Pratasik, 2017; Maulita *et al.*, 2018; Hutagaol *et al.*, 2019). Only a few studies from the biological aspect (Mujiono, 2013; Susiana & Rochmadi, 2018; Wulandari, 2018; Ayorbaba *et al.*, 2019). Indonesian waters are rich in various species of cephalopods. A number 44 of cephalopods' species based were recorded from the specimen collections housed at Diponegoro University, Semarang (Ghofar, 1999). Mujiono (2009) reported that at least 29 species of cephalopods were described based on the specimens collected from Indonesian waters. Specimen collection is the primary source to conduct a systematic study. Museum Zoology Bogor (MZB) established in 1894. Millions of zoological specimens housed in this institution, including hundreds of cephalopods.

One branch of the biological study is the systematic or taxonomy. This field studying the relationship between every living being based on the similarity of characters they have, such as

morphology, anatomy, genetic, behaviour, and also habitat. Taxonomy is a dynamic science, meaning that this science continues to develop along with technological developments. This science plays an important role in studying the diversity of life. Cephalopod's systematic is still being developed follows the advancement of other supporting field such as morphology, anatomy, and genetic. Roper *et al.*, (1984) classified all living cephalopods into two subclasses and five orders. Nautiloidea with single order Nautilida. Coleoidea with four orders, Sepiida, Teuthida (with two sub-orders, Myopsida and Oegopsida), Vampyromorpha, and Octopoda (with two sub-orders, Cirrata and Incirrata). Jereb & Roper (2005) adopted this system. They classified Nautilida into single family Nautilidae, Sepiida with five families, Sepiidae, Sepiolidae, Sepiadariidae, Idiosepiidae and Spirulidae. Jereb & Roper (2010) splitted and placed Myopsida and Oegopsida as different order, while Teuthida is no longer exist. Jereb *et al.*, (2014) conserved the previous system by Roper *et al.*, (1984) and placed Vampyromorphida and Octopoda as the order rank.

At present, Cephalopod's systematic is still being developed using several approaches. Lindgren *et al.*, (2004) combined the morphological and molecular approaches on their phylogenetic analysis using nine orders (Nautilida, Sepiida, Sepiolida, Spirulida, Idiosepiida, Teuthida, Octopoda, Cirroctopoda, and Vampyromorpha). Allcock *et al.*, (2014) reviewed the contribution of molecular data to Cephalopod systematics. Nine orders were analyzed, excluding Nautilida and including Bathyteuthida. Allcock (2015) made a comparative study on ten orders, excluding Cirroctopoda and including Myopsida and Oegopsida. Uribe & Zardoya (2017) revised the phylogeny of Cephalopoda using complete mitochondrial genomes from six orders (Nautilida, Vampyromorpha, Octopoda, Teuthida, Sepiida, and Spirulida). Different from all the previous studies which applied phylogenetic analysis, Pandey *et al.*, (2019) used the phenetic classification to study Kimmeridgian ammonites from India.

Phenetic is one method that still commonly used in the cephalopods' systematic today. This method treat all the observable character in the same level, regardless of the order during the evolutionary process. This method is more simple to study compare with phylogenetic method, and also applicable for living and fossil taxa. Our present study will follow the methods of Pandey *et al.*, (2019) and applied to Indonesia recent species of cephalopoda. The aim is to analyze the phenetic relationship of six known orders of cephalopoda based on the similarity of morphological characters that represented by one species in each order.

MATERIALS AND METHOD

The specimens of Cephalopoda housed in MZB were used as the object of this study. Only good preserved specimens used. Because this study intended to introduce the morphology (not the anatomy), the specimens dissected to show the buccal mass and funnel parts. No internal organ inside the stomach or inside the head will be discussed in this study.

We selected one species as a representative of each known orders, except for Vampyromorpha because no representative specimen available in MZB. Nautilida : *Nautilus pompilius*, MZB.Ceph.020. Manado, North Sulawesi. Spirulida : *Spirula spirula*, MZB.Ceph.053. Aceh. Sepiida : *Sepia pharaonis*, MZB.Ceph.127. Pegatan, South Kalimantan. Teuthida : *Loligo duvaucelli*, MZB.Ceph.035. Madura, East Java. Octopoda : *Octopus vulgaris*, MZB.Ceph.032. Aru Island, Molucca. Figure 1 depicting the map of locality of each specimens

The morphology (body part that has easily seen without dissecting the specimen) of "CSG" was photographed using a camera for the large body parts and using a microscope for the small body parts. We referred to the morphological terms used by Roper *et al.*, (1984) and Jereb & Roper, (2005). The analysis was conducted based on the comparative study of 11 morphological characters used in the taxonomic distinction between six known orders (Jereb & Roper, 2005). The morphological parts that useful for taxonomic distinction will be tabulated and coded in numeric (0, 1, 2) to make the comparative study easier (Pandey *et al.*, 2019). The data table was transposed before analyzed in cluster analysis using the Jaccard index applied in PAST 2.17 (Hammer *et al.*, 2001).



Figure 1. Map of locality of examined specimens in this study

RESULT AND DISCUSSION

Cephalopoda had one specific character with arms attached to the head. Only Nautilida secreting the external shell from the mantle. Spirulida does bear a shell, however, it cannot cover the whole body as in Nautilida. Shell in the other four members modified into a supporting protective shield, such as cuttlebone in Sepiida and gladius in Teuthida. Even in Octopoda and Vampyromorpha were reduced or disappear. Fins absent in Nautilida and Octopoda, they swim using the jet propulsion mechanism from the funnel organ or crawling along the bottom on the arms. The mouth has a pair of chitinous jaws called the beaks. The number of arms varied, 94 in Nautilida, 10 in Sepiida and Teuthida, eight in Octopoda and Vampyromorpha. Tentacle, a modified arm to catch prey, absent in Nautilida, Octopoda, and Vampyromorpha. Arm in Nautilida lack of sucker. Hectocotylus, a modified arm to insert sperm via ligula (male only), absent in Nautilida. The web between arms only present in Vampyromorpha. Ink sac absent in Nautilida and Vampyromorpha. This organ is producing ink that will be pumped out via a funnel organ. Ink is black, make the water dark. By that time they swim to escape from the enemy or predator.

Before explaining further, we will introduce some of the morphological terms used in the figures : am : arms, c : calamus, ca : chambers, f : funnel, fn : fin, h : hood, l : ligula, m : mantle, mc : main chamber, s : shell, se : septum, si : siphuncle, t : tentacle, tc : tentacle club, u : umbilicus, w : web, 1 : first arm, 2 : second arm, 3 : third arm, 4 : fourth arm. We made a tabulation (Table 1) based on the detail of morphological description from six orders as described in the previous paragraph. Mostly with binary code, except in arms (no.5) with three codes (0, 1, 2). The codes then analyzed to construct phylogenetic relationship among them (Figure 2).

The Nautilus' shell is advanced because of spirally coiled. The oldest part located in the centre and forming a small hole (umbilicus) that sealed by calcium secretion from the mantle organ. The shell is rigid and segmented by septums and forming numerous chambers. A newly born animal already has a shell with seven chambers. As they grow, a new chamber is continuously formed between 43-77 days. A fully mature animal has at least 39 chambers, including the last and largest chamber where their body is kept, called the main chamber (Landman *et al.*, 1989). Mature in 15 years before dying in 20 years. On average, shell diameter up to 230 mm and animal weight up to 1.675 g. A small hole (siphuncle) is present in the middle of the septum to connect between chambers. The shell itself has two main functions as protection and buoyancy. When threatened, they hide inside the main chamber and seal the body with their hood. Lacking fin, they used the arms for a swim. In the absence of an ink sac, swimming or hiding inside the shell is the only mechanism to escape from the enemy or predator. Unlike their relatives whose only have 8-10 arms, Nautiluses have 94 arms of a similar size, without tentacle. Their arms lack suckers and hooks (Jereb & Roper, 2005) (Figure 3: A-D).

Table 1. Comparative morphology and coding of six Cephalopoda orders

Characters	Nautilida	Teuthida	Sepiida	Spirulida	Octopoda	Vampyromorpha
1. shell	external (0)	internal (1)	internal (1)	internal (1)	internal (1)	internal (1)
2. coiling	present (1)	absent (0)	absent (0)	present (1)	absent (0)	absent (0)
3. design	advanced (1)	advanced (1)	advanced (1)	advanced (1)	reduced (0)	reduced (0)
4. rigidity	rigid (1)	flexible (0)	rigid (1)	rigid (1)	flexible (0)	flexible (0)
5. arms	94 (2)	10 (1)	10 (1)	10 (1)	8 (0)	8 (0)
6. suckers	absent (0)	present (1)	present (1)	present (1)	present (1)	present (1)
7. tentacle club	absent (0)	present (1)	present (1)	present (1)	absent (0)	absent (0)
8. retractable	absent (0)	absent (0)	present (1)	absent (0)	absent (0)	absent (0)
9. fins	absent (0)	present (1)	present (1)	present (1)	absent (0)	present (1)
10. ink sac	absent (0)	present (1)	present (1)	present (1)	present (1)	absent (0)
11. webs	absent (0)	absent (0)	absent (0)	absent (0)	present (1)	present (1)

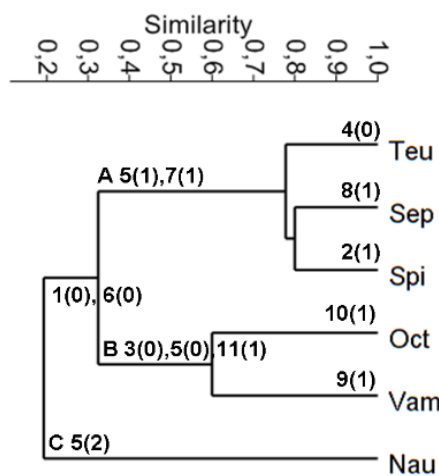

Figure 2. Phenetic relationship of six orders of Cephalopoda based on morphological characters. Number without parentheses is the character number, with parentheses is the character state. Teu (Teuthida), Sep (Sepiida), Spi (Spirulida), Oct (Octopoda), Vam (Vampyromorpha), Nau (Nautilida).

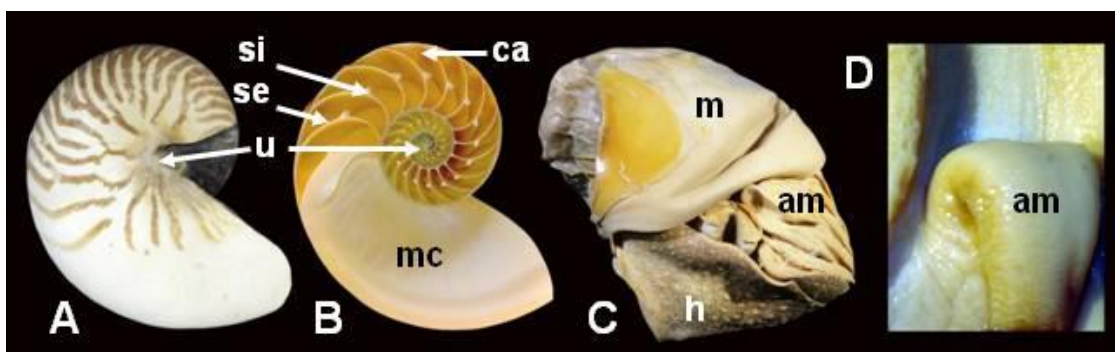

Figure 3. Morphology of Nautilida. A. left side of the shell, B. shell's lateral cut-off (source from www.buytheseaonline.com, with modification), C. whole of the body (in natural is positioned upside down), D. arm.

Nautilida is a living fossil because they emerge in the Upper Cambrian period (over 500 million years ago). It consists of one family and six valid species. The only cephalopods that secretes shell from their mantel organ. They are classified in the subclass Nautiloidea, while the other five

orders are in the subclass Coleoidea. Biogeographically, modern nautiloids are restricted to the Indo West Pacific. Only three species were distributed in Indonesian waters. *Nautilus pompilius* is the most widely distributed, *N. stenomphalus* rarely been seen because only distributed between eastern Australian and Papuan waters, and *Allonautilus perforatus* is the rarest species that only occur in Balinese waters (Jereb & Roper, 2005; Allock, 2017).

Spirulida is also a living fossil because they emerge in the latest Jurassic age. It consists of one family and one valid species. They are widely distributed in the tropical ocean between 50oN and 40oS. The animal is small, mantle length around 45 mm. Ink sac is present. They have eight arms with suckers and a pair of prolonged but unretractable tentacles with tentacle club. A rigid and coiled shell present at the bottom of the mantle. Two small fins present on the right and left of the shell. The coiled shell is different from *Nautilus* because not spirally connected, lack umbilicus nor siphuncle, and without the main chamber. However, the shell also vital for their buoyancy. Shell is comprised of over 30 chambers in adults. Mature in 12-15 months before dying in 18-20 months (Jereb & Roper, 2005; Price *et al.*, 2009) (Figure 4: A-C).

Sepiida is composed of four families and 195 valid species. Sepiida widely distributed in all oceans and seas of the world. At least 31 species of known to occur in Indonesian waters. The length of the mantle is slightly longer than the width. Maximum mantle length in adult animals ranges from 10 to 500 mm. Animal weight range from 1 gram to 12 kg. Ink sac is present. They have eight arms with suckers and a pair of prolonged and retractable tentacles with tentacle club. Arms, except tentacles, are shorter than the mantle length. Tentacles can be much longer than the mantle length. Shell modified into cuttlebone, a thick, rigid, and calcareous structure in the dorsal side of the mantle. Fins not wide, equal in length to the mantle length. Maturation varied at very different sizes and ages. Lifespan between 18-24 months (Jereb & Roper, 2005) (Figure 5: A-D).

Teuthida is consists of 29 families and 309 valid species. At least 55 species of Teuthida are known to occur in Indonesian waters. Mantle length can be much longer than the width. Mantle length varied from 20 mm to more than 3 m, weight from 20 gram to more than 500 kg. Ink sac is present. They have eight arms with suckers and a pair of prolonged and retractable tentacles with tentacle club. Arms frequently longer than the mantle length. Tentacles unretractable and can be much longer than the mantle length. Shell modified into gladius, a thin, flexible, and chitinous structure in the dorsal side of the mantle. Fins wide, rarely equal in length to the mantle length. This order can be separated into two suborders based on the eye's morphology. Myopsida is near-shore (neritic) squids, eyes covered with a corneal membrane. Oegopsida is an oceanic (pelagic) squids, eyes without a corneal membrane. Both are widely distributed near shore in all oceans and seas of the world. Maturation varied at very different sizes and ages. Lifespan between 6 months in smaller species to 14 years in gigantic species (Jereb & Roper, 2010) (Figure 5: E-J).

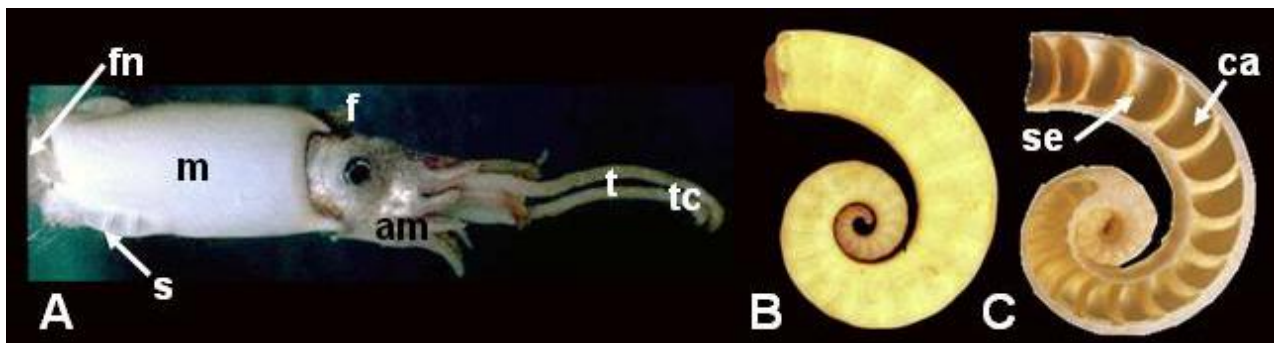

Figure 4. Morphology of Spirulida. A. whole of the body (source from www.tolweb.org, with modification), B. right side of the shell, C. shell's lateral cut-off.

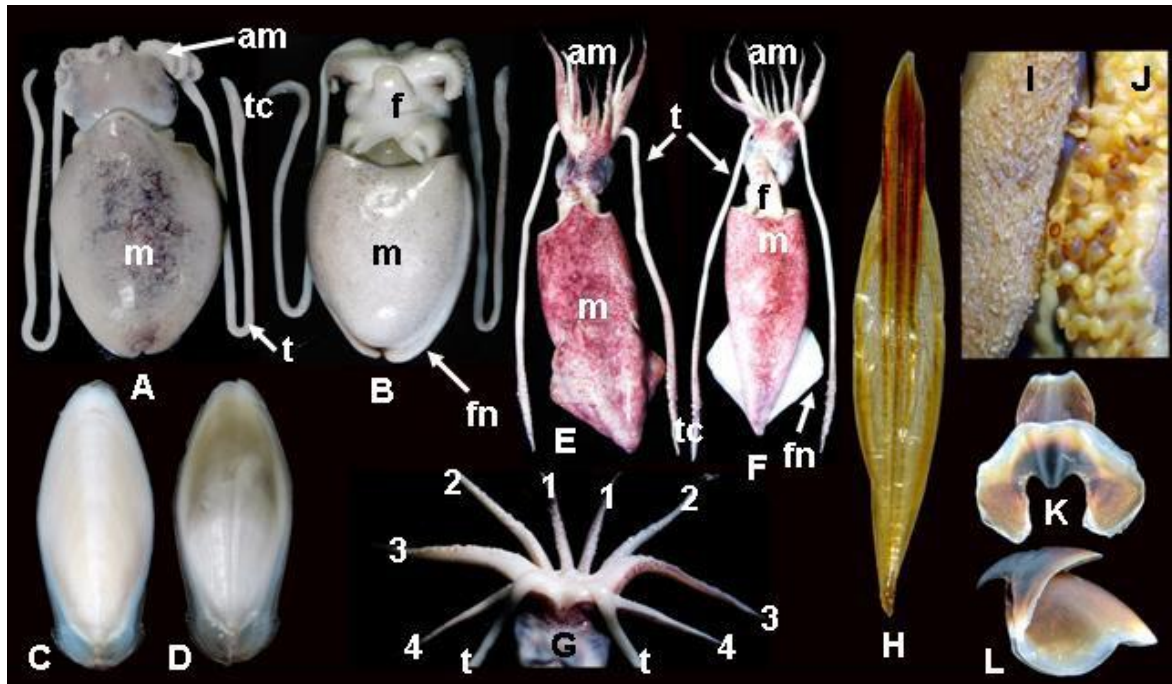

Figure 5. Morphology of Sepiida (A-D) and Teuthida (E-L). A. dorsal view, B. ventral view, C. cuttlebone (dorsal view), D. cuttlebone (ventral view), E. dorsal view, F. ventral view, G. arrangement of arms and tentacles, H. gladius, I. sucker of tentacle club, J. sucker of the arm, K. outer beak, L. inner beak.

Octopoda is composed of 14 families and 290 valid species. Octopoda widely distributed in all oceans and seas of the world. At least 27 species of Octopoda are known to occur in Indonesian waters. Mantle length only slightly longer than the width. Mantle length varied from 18 to more than 600 mm, weight from 1 gram to more than 100 kg. Ink sac is present. Arms frequently longer than the mantle length. Webs present in few number species. Without tentacle club and fin. Shell reduced into a small, weight round and chitinous structure inside the mantle. Mature at around three months of age and have an estimated lifespan of 12 to 15 months (Jereb *et al.*, 2014) (Figure 6: A-B).

Vampyromorpha is consists of a single-family and one valid species. They widely distributed in tropical and temperate waters worldwide, between approximately 35°N and 35°S. Mantle length only slightly longer than the width. Mantle length to 130 mm, weight unknown since it is a deep-sea species and rarely being caught. Ink sac is absent. Arms frequently longer than the mantle length. Webs present at very deep, extend to near arm tips. Have no tentacle club. Fin present, two pairs on juveniles and become one pair on adults. Shell reduced into eight small, round and chitinous structure inside the mantle. Maturation and lifespan are unknown (Jereb *et al.*, 2014) (Figure 6: C).

Cephalopoda can be split into two sub-classes. The first is Nautiloidea, which comprises of only one order, the Nautilida (Figure 2, group C). Three main characters are bearing external shell and 94 arms that lack suckers. The other sub-class is Coleoidea which comprised of five orders. Coleoidea branched into two groups. Teuthida, Sepiida, and Spirulida are grouped into the super-order Decapodiformes (Figure 2, group A) which means bearing ten arms (including a pair of tentacle club). Each order has a specific character. Teuthida with flexible internal shell (gladius). Sepiida with retractable tentacles. Spirulida with coiled shell. Octopoda and Vampyromorpha are grouped into the super-order Octopodiformes (Figure 2, group B) which means bearing eight arms (without tentacle club). Octopoda bearing ink sac but lack fins, while Vampyromorpha bearing fins but lack of ink sac. The webs are present in Vampyromorpha and few number species of Octopoda.

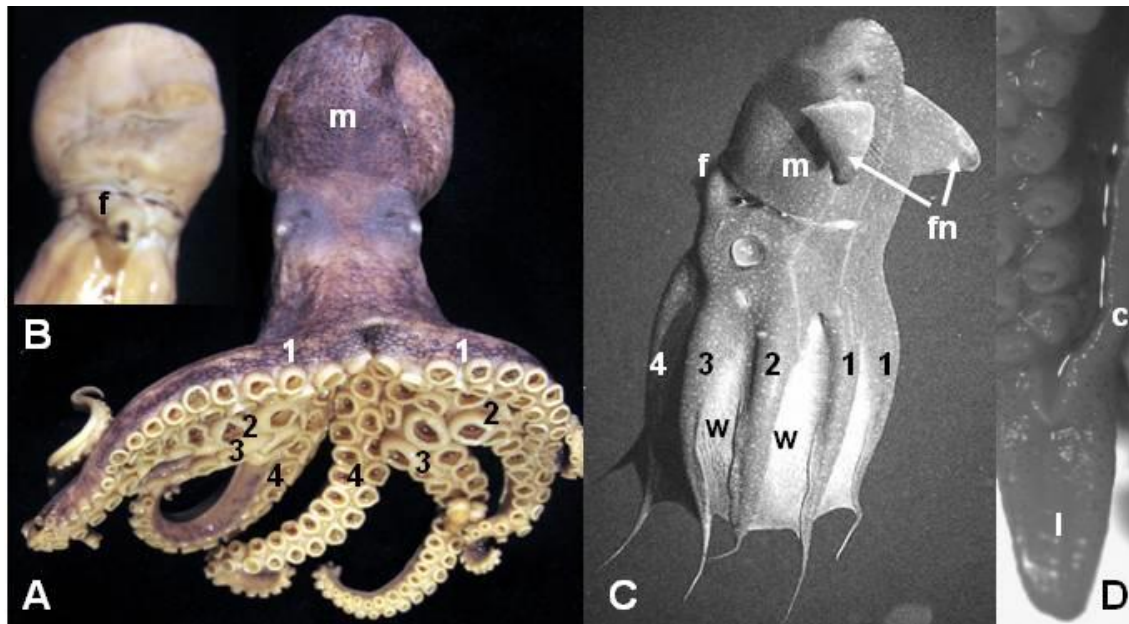

Figure 6. Morphology of Octopoda (A, B) and Vamphyromorpha (C). A. dorsal view, B. ventral view, C. dorsal view (source from www.mbari.org, with modification), D. hectocotylus (only in male).

CONCLUSION

Museum specimen can be used as the object when studying the systematic of Cephalopoda. The taxonomy and phenetic relationship are more easily learned based on their morphological characters. The living Cephalopoda is classified into two sub-classes based on their morphological characters. Nautiloidea is consist of only Nautilida, a group whose bearing external coiled shell and arm without suckers. The other five orders are classified in Coleoidea, a group whose internal reduced shell and arm with suckers.

ACKNOWLEDGEMENT

The author would like to thank Alfiah and Riena Prihandini for their assistance during laboratory work in The Museum Zoology Bogor. The reviewers who have constructive advice are greatly acknowledged.

REFERENCES

- Allcock, A.L., Lindgren, A. & Strugnell, J.M. (2014). The contribution of molecular data to our understanding of cephalopod evolution and systematics: a review. *Journal of Natural History*, 49(21-24), 1373-1421. <https://doi.org/0.1080/00222933.2013.825342>.
- Allock, L.A. (2015). Systematics of Cephalopods. In P. Gopalakrishnakone & A. Malhotra (Eds.), *Evolution of venomous animals and their toxins*. (pp. 415-434). The Netherlands: Springer. https://doi.org/10.1007/978-94-007-6458-3_8.
- Ayorbaba, A.E., Widiastuti, N., Ananta, A.S., & Boli, P. (2019). Aspek biologi cumi-cumi (*Loligo* sp.) yang tertangkap oleh nelayan di perairan Manokwari. *Jurnal Sumberdaya Akuatik Indopasifik*, 3(1), 65-73.
- Ghofar, A. (1999). Indonesian seas cephalopods: a collection of Fisheries Laboratories Diponegoro University. *Journal of Coastal Development*, 2(2), 347-454.

- Hammer, Ø., Harper, D.A.T., & Ryan, P.D. (2001). PAST: Paleontological Statistics Software Package for Education and Data Analysis. *Palaeontologia Electronica*, 4(1), 1-9.
- Hutagaol, I.D., Redjeki, S., & Susilo, E.S. (2019). Morfometri *Octopus vulgaris* Cuvier, 1797 (Cephalopoda : Octopodidae) dari Perairan Popisi, Pulau Banggai Laut, Sulawesi Tengah. *Journal of Marine Research*, 8(2), 149-156. <https://doi.org/10.14710/jmr.v8i2.25095>.
- Jereb, P., & Roper, C.F.E. (eds). (2005). Cephalopods of the world. An annotated and illustrated catalogue of cephalopod species known to date. Volume 1. Chambered nautilus and sepioids (Nautilidae, Sepiidae, Sepiolidae, Sepiadariidae, Idiosepiidae and Spirulidae). FAO Species Catalogue for Fishery Purposes, 4(1). Rome: FAO.
- Jereb, P., & Roper, C.F.E. (eds). (2010). Cephalopods of the world. An annotated and illustrated catalogue of cephalopod species known to date. Volume 2. Myopsid and Oegopsid Squids. FAO Species Catalogue for Fishery Purposes. No. 4, Vol. 2. Rome: FAO. <http://www.fao.org/publications/card/en/c/42d0f8a9-1696-5dcb-a323-e8303399a472>.
- Jereb, P., Roper, C.F.E., Norman, M.D., Finn, J.K. (2014). Cephalopods of the world. An annotated and illustrated catalogue of cephalopod species known to date. Volume 3. Octopods and Vampire Squids. FAO Species Catalogue for Fishery Purposes. No. 4, Vol. 3. Rome: FAO.
- Landman, N.H., Cochran, J.K., & Chamberlain, J.A. (1989). Timing of septal formation in two species of *Nautilus* based on radiometric and aquarium data. *Marine Biology*, 102, 65-72. <https://doi.org/10.1007/BF00391324>.
- Lindgren, A.R., Giribet, G., & Nishiguchi, M.K. (2004). A combined approach to the phylogeny of Cephalopoda (Mollusca). *Cladistics*, 20, 454-486. <https://doi.org/10.1111/j.1096-0031.2004.00032.x>.
- Marthinus, S., & Ahmad, T. (1996). Pengaruh ransum pakan yang berbeda terhadap sintasan dan pertumbuhan Sotong Buluh (*Sepioteuthis lessoniana* Lesson). *Jurnal Penelitian Perikanan Indonesia*, 2(4), 76-81. <http://doi.org/10.15578/jppi.2.4.1996.76-81>.
- Maulita, M., Ashari, D., Samsuharapan, S.B., Sabariah, N., Abidin, G.Z., & Mulyono, M. (2018). Biological and fisheries aspect of *Octopus* sp. (Cephalopoda) from the waters of Buton Regency, Southeast Sulawesi, Indonesia. *International Journal of Fisheries and Aquatic Studies*, 6(1), 106-110.
- Ministry of Marine and Fisheries. (2018). Performance of 4 years of government of Joko Widodo-Jusuf Kalla. Marine and Fisheries Sector. Power Point presentation. <https://docplayer.info/134292991-Kinerja-4-tahun-pemerintahan-jokowi-jk-sektor-kelautan-dan-perikanan.html>.
- MolluscaBase (eds). (2021). *MolluscaBase*. Retrieved January 5, 2021, from <http://www.molluscabase.org>.
- Mujiono, N. (2009). Spesimen tipe cephalopoda dari perairan Indonesia. *Oseana*, 34(4), 9-15.
- Mujiono, N. (2013). *Idiosepius* Steenstrup, 1881 cumi-cumi kerdil dari perairan Indonesia (Cephalopoda : Idiosepiidae). *Fauna Indonesia*, 12(2), 38-42.
- Muchlisin, Z.A., Zulkarnaini, B., Purnawan, S., Muhadjier, A., Fadli, N., & Cheng, S.H. (2014). Morphometric variations of three species of harvested cephalopods found in northern sea of Aceh Province, Indonesia. *Biodiversitas*, 15(2):142-146. <https://doi.org/10.13057/biodiv/d150205>.
- Pandey, D.K., Das, R., Alberti, M., Fürsich, F.T., Shekhawat, R.S., Udupa, P. (2019). Phenetic classification of Kimmeridgian ammonites from the eastern Kachchh Basin, India. *PalZ*, 93, 255-263.
- Pratasik, S.B., Marsoedi, A.D., & Setyohadi, D. (2017). Egg placement habitat selection of cuttlefish, *Sepia latimanus* (Sepiidae, Cephalopoda, Mollusca) in North Sulawesi waters, Indonesia. *AACL Bioflux*, 10(6), 1514-1522.
- Price, G.D., Twitchett, R.J., Smale, C., & Marks, V. (2009). Isotopic analysis of the life history of the enigmatic squid *Spirula spirula*, with implications for studies of fossil cephalopods. *Palaios*, 24(5/6), 273-279. <https://doi.org/10.2110/palo.2008.p08-067r>.
- Roper, C.F.E., Sweeney, M.J. & Nauen, C.E. (1984). FAO species catalogue. Vol. 3. Cephalopods of the world. An annotated and illustrated catalogue of species of interest to fisheries. FAO Species Catalogue for Fishery Purposes. FAO: Rome. 1(4), 277p.

- Samudra, N.R., Hartoko, A., & Sulardiono, B. (2016). Hubungan salinitas terhadap perkembangan telur cephalopoda yang didapat pada perairan Pantai Bondo Kabupaten Jepara. *Diponegoro Journal of Maquares*, 5(2), 70-79.
- Susiana., Rochmady. (2018). Pendugaan Stok Cumi-cumi *Loligo* sp. di Perairan Kabupaten Pangkajene dan Kepulauan, Sulawesi Selatan, Indonesia. *Jurnal Pengelolaan Perairan*, 1(1), 14-30.
- Sweeney, M.J., & Roper, C.F.E. (1998). Classification, type localities, and type repositories of recent Cephalopoda. *Smithsonian Contributions to Zoology*, 586 (*Systematics and Biogeography of Cephalopods*), 2, 561-599. <https://doi.org/10.5479/si.00810282.586.277>.
- Theresia, S.M., Pramonowibowo, & Wijayanto, D. (2013). Analisis Bioekonomi Perikanan Cumi-Cumi (*Loligo* sp) Di Pesisir Kabupaten Kendal. *Journal of Fisheries Resources Utilization Management and Technology*, 2(3), 100-110.
- Uribe, J.S. & Zardoya, R. (2017). Revisiting the phylogeny of Cephalopoda using complete mitochondrial genomes. *Journal of Molluscan Studies*, 83, 133-144. <https://doi.org/10.1093/mollus/eyw052>.
- Wulandari, D.A. (2018). Morfologi, klasifikasi, dan sebaran cumi-cumi famili Loliginidae. *Oseana*, 43(2), 48-65. <https://doi.org/10.14203/oseana.2018.Vol.43No.2.21>.